



*The People You Know. The Products You Trust.*

# B400

- LARGE CAPACITY HOPPER
- LOW NOISE
- EXCELLENT VISIBILITY
- EQUIPPED WITH A LOW FUEL CONSUMPTION
- VERY COMFORTABLE OPERATION POSITION



**QUALITY – PERFORMANCE –  
PUBLIC SAFETY – VALUE –  
CUSTOMER SUPPORT**

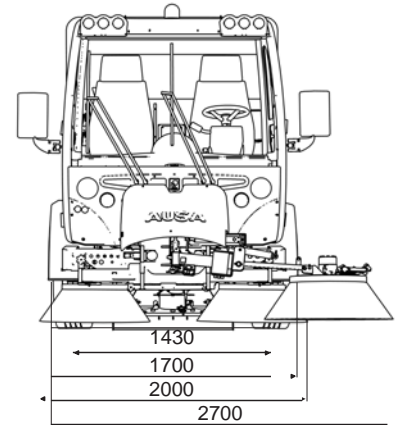
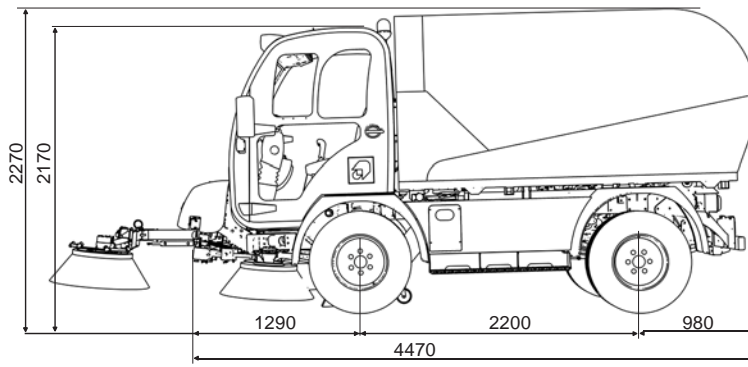

## TECHNICAL SPECIFICATIONS

		B 400 H x2 l x4
Waste hopper	ALUMINIUM Capacity (m <sup>3</sup> )	4 m <sup>3</sup>
Water tank	INOX Capacity (l)	500 l (INOX)
Sweeping system	Vacuum power (m <sup>3</sup> /h)	13000 m <sup>3</sup> /h
	Brooms	2 standard brooms of 0 850 mm / 3rd optional broom 0 850 mm
Vacuum nozzle	Sweeping path width (mm)	2000mm / 2700mm with 3rd optional broom
		Nozzle width 800 mm Adjustable gate Stainless steel
Engine	Make	VOLKSWAGEN
	Type	2.01 TDI EURO 5
	Emission regulations	EURO 5
	Power (Kw - Cv)	75-102 (3000 rpm)
	N. of cylinders	4
	Cooling	Liquid
Tank capacity (l)	Fuel	85
	Unloading system	
Hopper discharge angle		50
	Backwards movement (mm)	200 mm
	Hopper dump height (mm)	1540 mm
Transmission		2 hydrostatic speeds + 2 mechanical speeds
	Maximum speed (Km/h)	Limited to 40 km/h / optional to 62 km/h or 25 km/h
Gradient negotiable (with full load)	Traction	4x2 rear locking differential on demand / 4x4 FULLGRIP® system and rear locking differential on demand
Brakes	Service	Power-assisted hydraulic master cylinder, disc on front wheels and drum brake on rear wheels (ABS + EBD Optional / Standard on version 62 km/h)
	Parking	On rear axle, mechanically applied, hydraulically released
Steering suspension		Hydraulically power-assisted steering, supplied by TRW
		On front axle, Hydraulic absorbers & springs
		On rear axle, Helicoidally leaf springs, hydraulic absorbers and anti-roll bar
Weight (Kg)	Unloaded weight	4440 (2355 front axle ; 2085 rear axle)
	Gross weight	6045 (2650 front axle ; 3750 rear axle)

## STANDARD EQUIPMENT

**Front brooms(2) broom side-shift (+/-200mm)**  
**Closed cabin with heating**  
**Doors with excellent visibility**  
**Electronic boost of rpm engine**  
**Monitor with 2 cameras: suction nozzle l backwards visibility**  
**Quick "LINK"® coupling l uncoupling fast system of optional interchangeable attachments for the sweeper**  
**Water coupling STORZ 2"**  
**Water couplings Barcelona 45 l 70**  
**Hose 5m**  
**Waste tank inspection window**  
**Seat with mechanical suspension**  
**Rotating beacon with telescopic support of 450mm length**  
**Electrically adjustable rear mirrors with heater**  
**Approved lightning system with electrical settings on head lamps**  
**Wheel wrench**  
**Wiring for transceiver set**  
**Radio**  
**Front plate for attachments**  
**Right hand drive for better sweeping visibility**

## OPTIONAL EQUIPMENT

**Sweeping water recirculation system**  
**3rd broom with long reaches (850mm)**  
**Auxiliary manual wander hose reaching up to 5 m l 0 160 mm**  
**High pressure water jet spray lance (150 bar l hose length 15m l possibility use of detergent)**  
**High pressure water jet spray lance with hose reel (150 bar l hose length 16m l possibility use of detergent)**  
**Standard support legs for taking-off the sweeping equipment**  
**Air conditioning**  
**Tacograph**  
**Seat with pneumatic suspension**  
**Towing hitch ball (50 mm) with electric socket (13 pins)**  
**Towing hitch "Rockinger" with electric socket (13 pins)**  
**Automatic lubrication system**  
**62km/h with ABS + EBD and 2 mechanical speed**  
**ABS + EBD (on 40km/h version)**  
**4 wheel drive**

AUSA reserves the right to make any changes in the specifications without prior notice.